

***Hardwick Electric Department***  
PO Box 516  
Hardwick, Vermont 05843  
(802) 472-5201 - (802) 472-3388  
Fax (802) 472-6769

## TABLE OF CONTENTS

- OVERHEAD SERVICE
  
- MAST OVERHEAD SERVICE
  
- TYPICAL TRENCH CROSS-SECTION – U.G CABLE IN CONDUIT
  
- FOUNDATION CONDUIT INSTALLATION
  
- FOUNDATION SINGLE PHASE TRANSFORMER BOX PAD
  
- SINGLE PHASE TERMINATION BOX
  
- TYPICAL METER PEDESTAL
  
- UNDERGROUND SERVICE
  
- POLE METERING

# OVERHEAD SERVICE

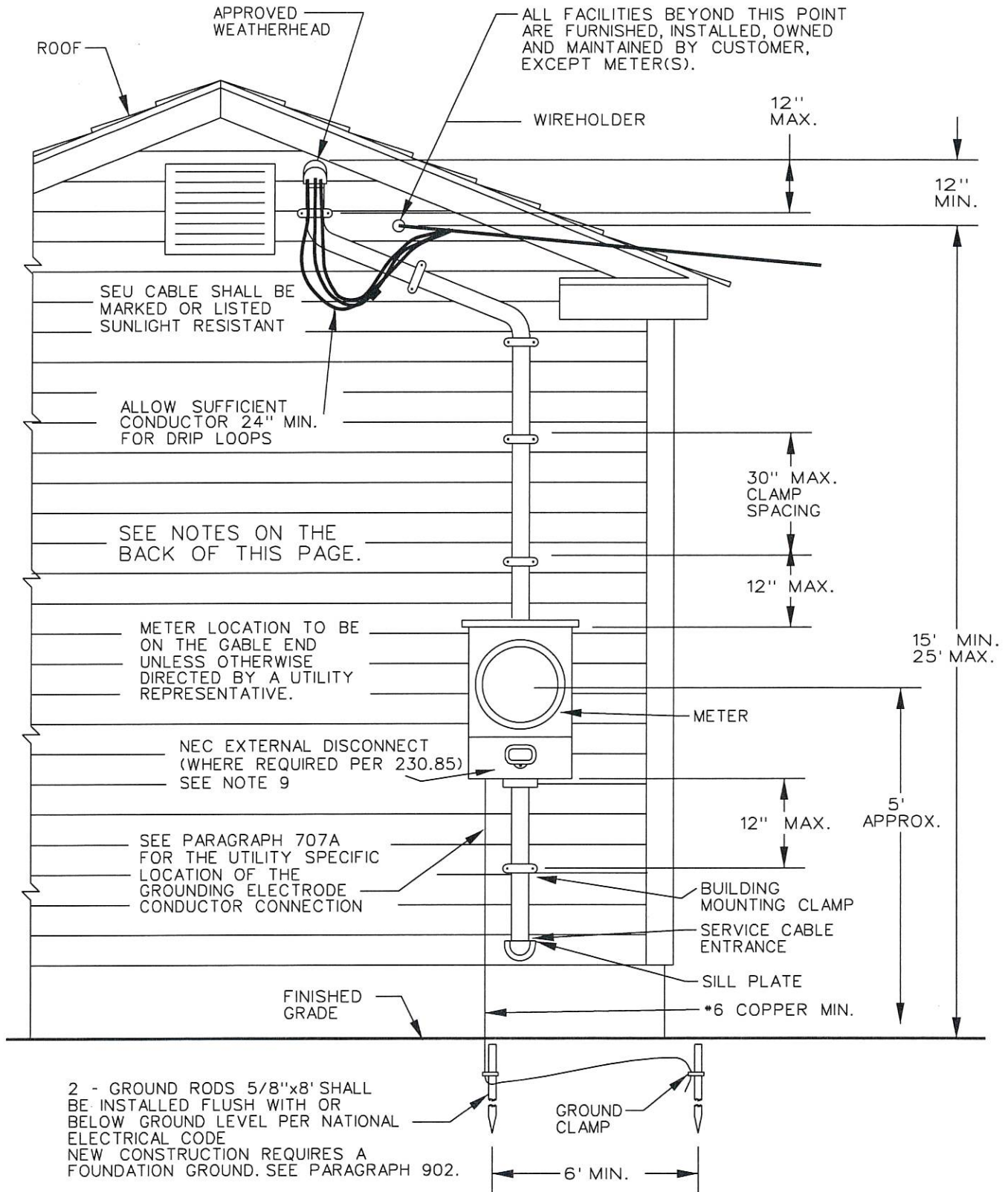

**VERMONT UTILITIES  
ELECTRIC SERVICE REQUIREMENTS**

DRAWN: <i>RJS</i>	DATE: 04-01-22
APPRVD: <i>YES</i>	DATE: 04-01-22
DRAWING No.: 101	PAGE: 1 of 2
DATA BASE No.: DTW01889e	

# OVERHEAD SERVICE

---

Notes:

1. All wiring and materials shall conform to the requirements of the National Electric Code (NEC) and to any applicable local codes. Where conflict exists the more stringent code will apply. For customer owned equipment, any requirements in excess of code specified minimums, are recommended not required.
2. The point of attachment of the service drop and the location of the meter socket will be designated by the utility representative. Any relocation shall be approved by a utility representative.
3. On low buildings, without the minimum 15 ft clearance, a mast installation shall be required (refer to mast installation drawing).
4. The service drop will not be allowed to be attached on or under the eaves.
5. In areas subject to truck traffic, the clearance required to the service drop, is a minimum of 16 ft, under the ice loading conditions described in the National Electric Safety Code (NESC). If the overhead service is owned by the customer, rather than the utility, the clearance required is a minimum of 18 ft under the conditions described in the NEC (no loading at 60E F). In areas only subject to pedestrian traffic, the clearance required to the service drop, is a minimum of 12 ft, under the ice loading conditions described in the NESC.
6. Residential 320 amp meter sockets, and all commercial meter sockets, shall have a manual bypass. For Utility-specific details see Paragraph 705E. See Paragraph 707 for requirements and Utility-specific details of how a Service Grounding Connection is to be made. See the Meter Socket Specification (Dwg 601) included in this manual.
7. The grounding electrode conductor, to a driven ground, shall be a minimum of #6 copper. The conductor shall be adequately protected. The driven rods shown shall be a minimum of 5/8" in diameter and 8' long. See Paragraph 901 through 905 for details of the Service Ground.
8. All gas valves shall be a minimum of 10 ft from electric meter equipment. For clearances less than 10 ft see Dwg. 401 and NFPA 58.
9. The Service Disconnecting Means shall be installed at a readily accessible location, either outside of a building or structure, or, inside a building or structure nearest the point of entrance of the service conductors, not to exceed 10 feet of conductor length, from the point of entrance. For one and two family dwelling units per the NEC section 230.85 this service disconnect must be located in a readily accessible outdoor location and be marked per the NEC requirements. This may be an integral meter/breaker or separate disconnect.
10. The service drop cable and its drip loop shall have a clearance of 3 ft from any accessible opening such as to the side of an openable window, to the top of a doorway to a balcony, or to the side of a fire escape. No clearance is required directly above a window. If the opening is used for access for people or materials, then service cables shall not be placed below the opening. See NEC Article 230.9.
11. All services, unless the exceptions of Notes 12 or 13 apply, shall have a clearance of 10 ft, from the roof. That clearance is required above the roof and 3 ft beyond the edge of the roof. The service drop may attach to the side of the building.
12. For roofs easily accessible to pedestrian or vehicular traffic, clearances are those required above ground surfaces. See Note 5.
13. For inaccessible roofs with a slope of 4 on 12, or steeper, and voltages less than 300 volts between conductors, the clearance to the roof may be reduced to 3 ft. A roof is considered accessible if it can be accessed by a window or permanently mounted ladder.

	<b>VERMONT UTILITIES ELECTRIC SERVICE REQUIREMENTS</b>	App'd: <i>YES</i> DATE: 12/20 101PG2E	<u>DRAWING NUMBER</u> 101 Page 2
---	--	---	-------------------------------------

# MAST OVERHEAD SERVICE

ALL FACILITIES BEYOND THIS POINT ARE FURNISHED, INSTALLED, OWNED AND MAINTAINED BY CUSTOMER, EXCEPT METER(S).

ALLOW SUFFICIENT CONDUCTOR 24" MIN. FOR DRIP LOOPS TYPE USE CABLE SHALL BE MARKED OR LISTED SUNLIGHT RESISTANT

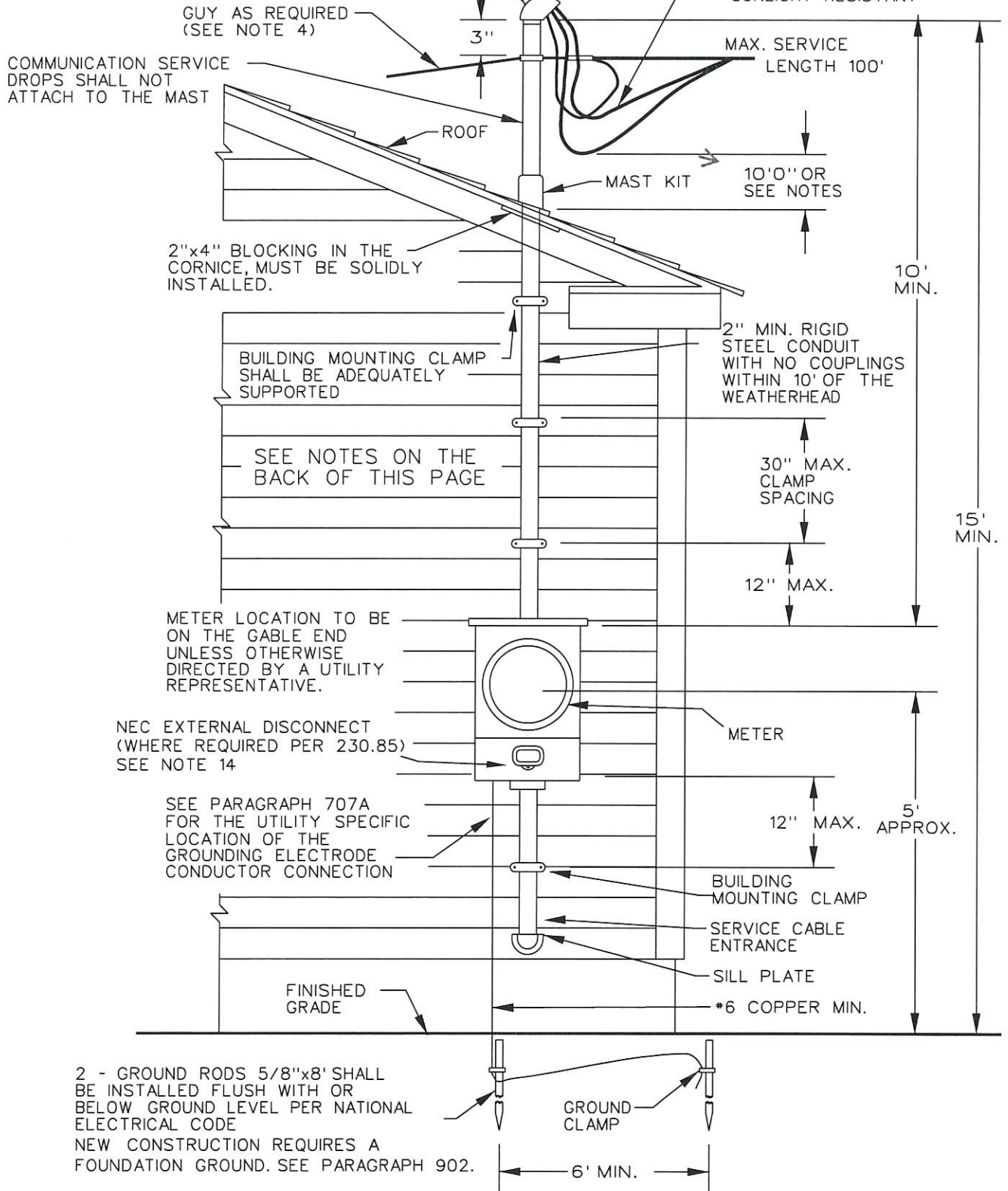

2 - GROUND RODS 5/8"x8' SHALL BE INSTALLED FLUSH WITH OR BELOW GROUND LEVEL PER NATIONAL ELECTRICAL CODE  
NEW CONSTRUCTION REQUIRES A FOUNDATION GROUND. SEE PARAGRAPH 902.

## VERMONT UTILITIES ELECTRIC SERVICE REQUIREMENTS

DRAWN: RJS	DATE: 04-01-22
APPRVD: JES	DATE: 04-01-22
DRAWING No.: 102	PAGE: 1 of 2
DATA BASE No.: DTW01890e	

# MAST OVERHEAD SERVICE

---

## Notes:

1. All wiring and materials shall conform to the requirements of the National Electric Code (NEC) and to any applicable local codes. Where conflict exists the more stringent code will apply. For customer owned equipment, any requirements in excess of code specified minimums, are recommended not required.
2. The location and height of the service mast and the location of the meter socket will be designated by the utility representative. Any relocation shall be approved by a utility representative.
3. All entrance wiring shall be completed prior to the utility placing the service drop. The customer assumes the responsibility that the mast is of adequate strength, and adequately braced, to support the strain of the service drop.
4. For mast heights above 3 ft, or service drops longer than 100 ft, the mast shall be guyed. Guying may be required on masts shorter than 3 ft. As an alternative, a larger than nominal conduit, may be required, to support the service drop, on masts shorter than 3 ft.
5. If circumstances result in the mast being located on the eaves side of the building, rather than the gable side, the meter socket shall be protected, by an overhang, or else wise, from water or ice falling from the eaves.
6. All services, unless the exceptions of Notes 7, 8 or 9 apply, shall have a clearance of 10 ft, from the roof. That clearance is required above the roof and 3 ft beyond the edge of the roof.
7. For roofs easily accessible to pedestrian or vehicular traffic, clearances are those required above ground surfaces. See Note 10.
8. For inaccessible roofs with a slope of 4 on 12, or steeper, and voltages less than 300 volts between conductors, the clearance to the roof may be reduced to 3 ft. A roof is considered accessible if it can be accessed by a window or permanently mounted ladder.
9. For mast service installations with a voltage less than 300 volts between conductors, the clearance to the roof may be reduced to 18 inches, provided no more than 6 ft of service drop crosses over the roof and provided the mast is no more than 4 ft from the edge of the roof.
10. In areas subject to truck traffic, the clearance required to the service drop, is a minimum of 16 ft, under the ice loading conditions described in the National Electric Safety Code (NESC). If the overhead service is owned by the customer, rather than the utility, the clearance required is a minimum of 18 ft under the conditions described in the NEC (no loading at 60E F). In areas only subject to pedestrian traffic, the clearance required to the service drop, is a minimum of 12 ft, under the ice loading conditions described in the NESC.
11. Residential 320 amp meter sockets, and all commercial meter sockets, shall have a manual bypass. For Utility-specific details see Paragraph 705E. See Paragraph 707 for requirements and Utility-specific details of how a Service Grounding Connection is to be made. See the Meter Socket Specification (Dwg 601) included in this manual.
12. The grounding electrode conductor, to a driven rod shall be a minimum of #6 copper. The conductor shall be adequately protected. The driven rods shown shall be a minimum of 5/8" in diameter and 8' long. See Paragraph 901 through 905 for details of the Service Ground.
13. All gas valves shall be a minimum of 10 ft from electric meter equipment. For clearances less than 10 ft see Dwg. 401 and NFPA 58.
14. The Service Disconnecting Means shall be installed at a readily accessible location, either outside of a building or structure, or, inside a building or structure nearest the point of entrance of the service conductors, not to exceed 10 feet of conductor length, from the point of entrance. For one and two family dwelling units per the NEC section 230.85 this service disconnect must be located in a readily accessible outdoor location and be marked per the NEC requirements. This may be an integral meter/breaker or separate disconnect.



## VERMONT UTILITIES ELECTRIC SERVICE REQUIREMENTS

App'd: *YES*  
DATE: 12/20  
102pg2e.doc

DRAWING NUMBER  
102 Page 2

# UNDERGROUND SERVICE

RESIDENTIAL SERVICES ONLY			
RATING	CABLE LENGTH*	TRIPLEX SIZE	CONDUIT
100 A	0-210 FT.	1/0	2 1/2"
	211-410 FT.	4/0	2 1/2"
	411-650 FT.	350 MCM	3"
150 A	0-275 FT.	4/0	2 1/2"
	276-435 FT.	350 MCM	3"
200 A	0-205 FT.	4/0	2 1/2"
	206-325 FT.	350 MCM	3"
300 A	0-220 FT.	350 MCM	3"

\* Cable Length is the total of trench and riser lengths. This chart does not indicate that the cable can be pulled into conduits of these lengths. Pulling tension calculations are necessary to make that determination.

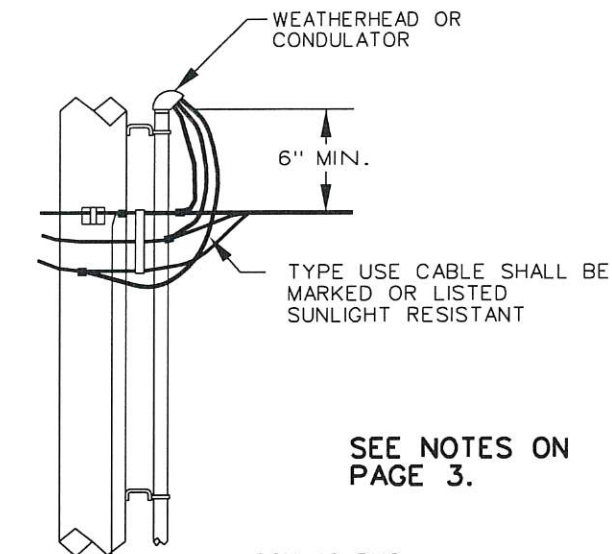

**SEE NOTES ON PAGE 3.**

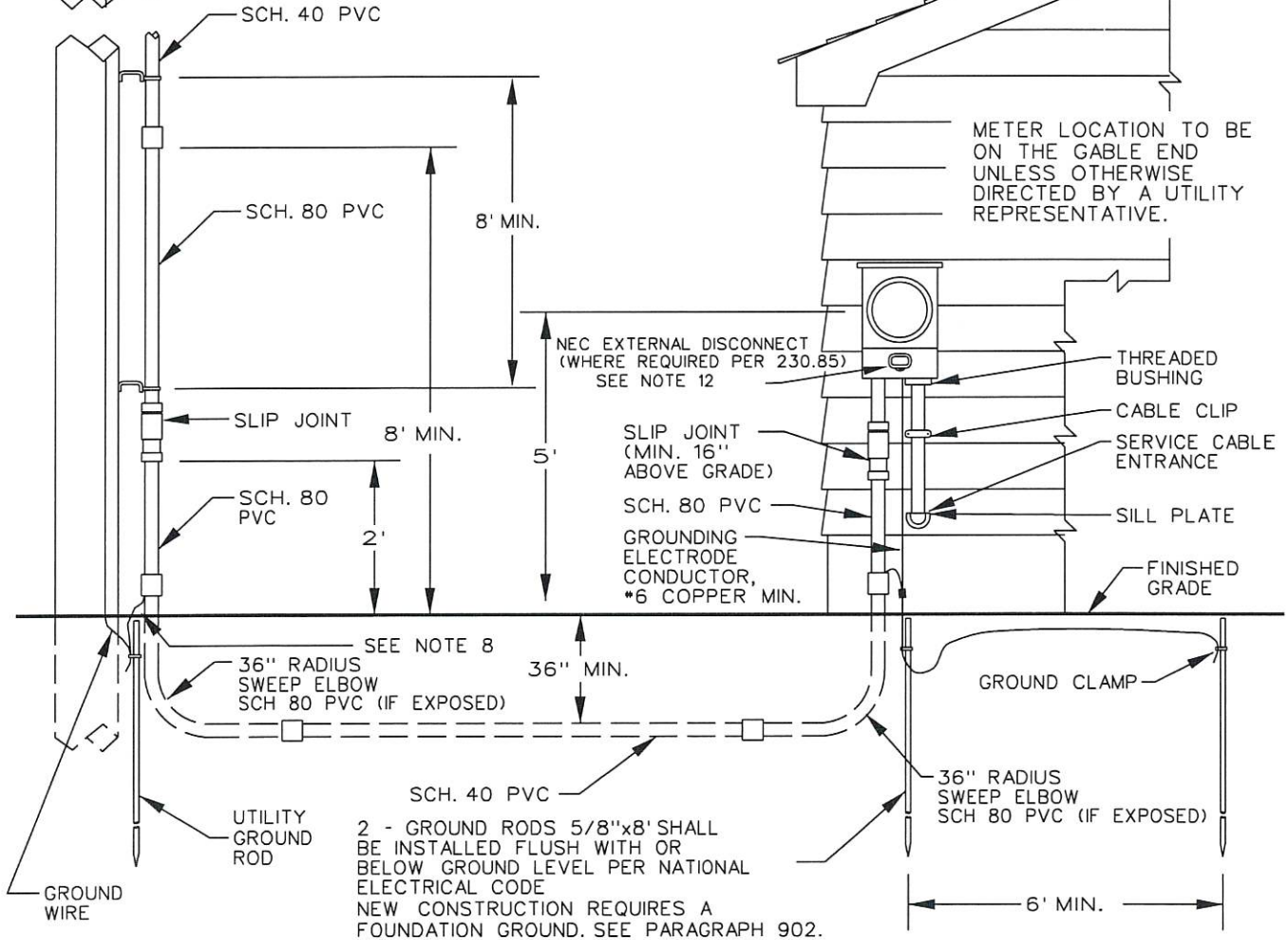

## VERMONT UTILITIES ELECTRIC SERVICE REQUIREMENTS

DRAWN: <i>RJS</i>	DATE: 04-01-22
APPRVD: <i>125</i>	DATE: 04-01-22
DRAWING No.: 201	PAGE: 1 of 3
DATA BASE No.: DTWO1891h	

# UNDERGROUND SERVICE

RESIDENTIAL SERVICES ONLY			
RATING	CABLE LENGTH*	TRIPLEX SIZE	CONDUIT
100 A	0-210 FT.	1/0	2 1/2"
	211-410 FT.	4/0	2 1/2"
	411-650 FT.	350 MCM	3"
150 A	0-275 FT.	4/0	2 1/2"
	276-435 FT.	350 MCM	3"
200 A	0-205 FT.	4/0	2 1/2"
	206-325 FT.	350 MCM	3"
300 A	0-220 FT.	350 MCM	3"

\* Cable Length is the total of trench and riser lengths. This chart does not indicate that the cable can be pulled into conduits of these lengths. Pulling tension calculations are necessary to make that determination.

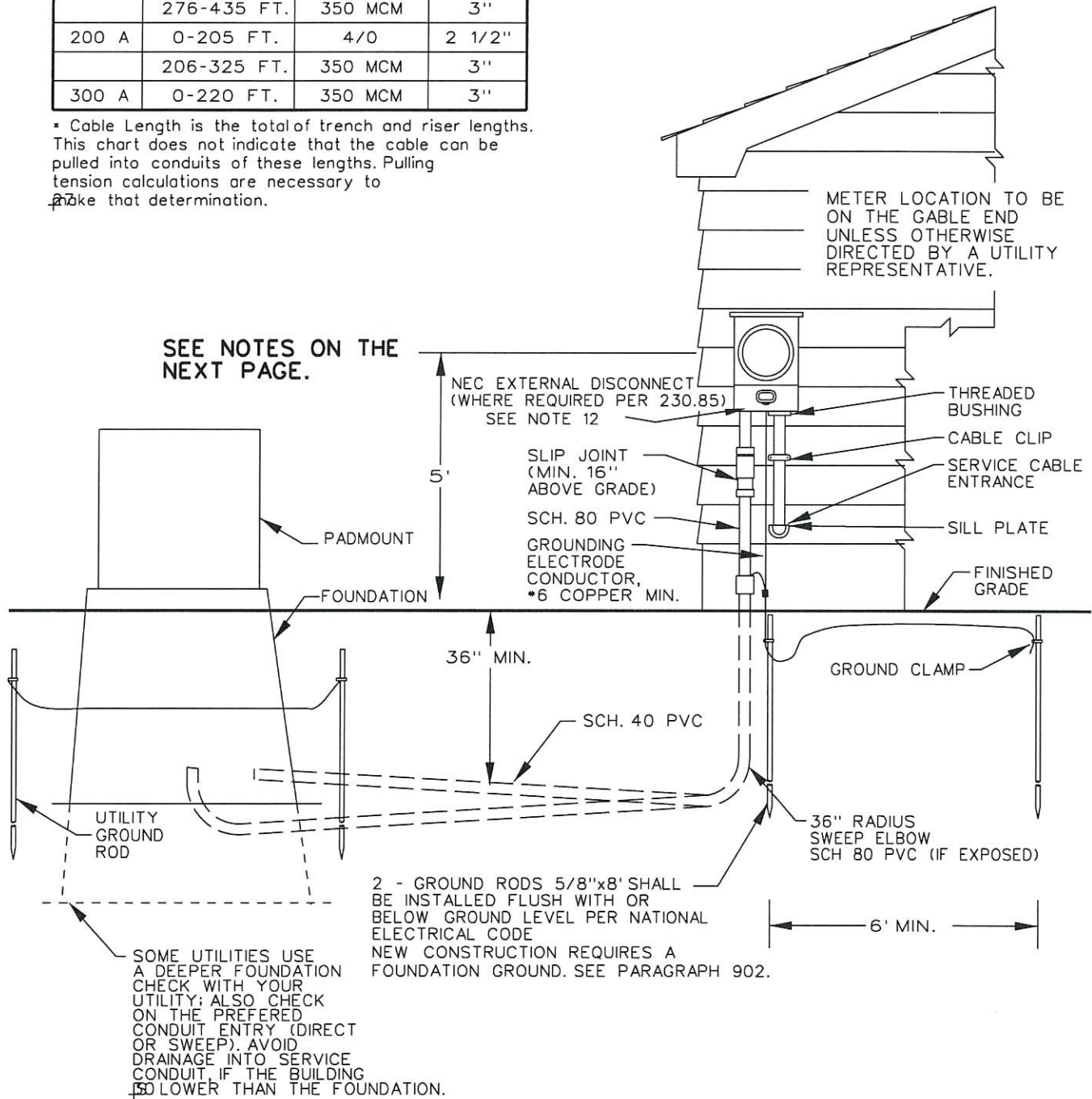

## VERMONT UTILITIES ELECTRIC SERVICE REQUIREMENTS

DRAWN: <i>RJS</i>	DATE: 04-01-22
APPRVD: <i>YES</i>	DATE: 04-01-22
DRAWING No.: 201	PAGE: 2 of 3
DATA BASE No.: DTW01891.2b	

# UNDERGROUND SERVICE

---

Notes:

1. All wiring and materials shall conform to the requirements of the National Electric Code (NEC) and to any applicable local codes. Where conflict exists the more stringent code will apply. For customer owned equipment, any requirements in excess of code specified minimums, are recommended not required.
2. This specification covers residential services. Commercial service equipment is under the jurisdiction of the electrical inspector. The cable sizes shown in the chart may not apply to commercial services.
3. The location of the conduit risers and the meter socket will be designated by the utility representative. Any relocation shall be approved by a utility representative.
4. Conduit Condulators may be required for multi-conductor services and for conductors of 350 MCM or larger. Exercise care in limiting water entry.
5. Locate the riser conduit on the quarter of the pole away from normal traffic.
6. Residential 320 amp meter sockets, and all commercial meter sockets, shall have a manual bypass. For Utility-specific details see Paragraph 705E. See Paragraph 707 for requirements and Utility-specific details of how a Service Grounding Connection is to be made. See the Meter Socket Specification (Dwg 601) included in this manual.
7. The grounding electrode conductor, to a driven ground, shall be a minimum of #6 copper. The conductor shall be adequately protected. The driven grounds shown shall be a minimum of 5/8" in diameter and 8' long. See Paragraph 901 through 905 for details of the Service Ground.
8. Any steel conduit within 18" of the surface shall be bonded. Steel conduit is not required.
9. Any construction, at the pole, above ground level, shall be done by the utility company. Exception: The customer may install that portion of their equipment that can be reached while standing on the ground. Any trench near the base of the pole shall be immediately backfilled and properly tamped.
10. Depths shallower than 36" may be allowed where obstructions such as ledge are encountered. Any portion of conduit shallower than 24" shall be covered by a minimum 2" concrete cap. See the utility for additional requirements for conduit buried near underground facilities, under driveways or roadways, or, for depths shallower than 12".
11. All gas valves shall be a minimum of 10 ft from electric meter equipment. For clearances less than 10 ft see Dwg. 401 and NFPA 58.
12. The Service Disconnecting Means for one and two family dwelling units per the NEC section 230.85 must be located in a readily accessible outdoor location and be marked per the NEC requirements. This may be an integral meter/breaker or separate disconnect.
13. The chart shows the acceptable total cable length for given service amp ratings and conductors. The chart is based on a maximum 3% voltage drop in an aluminum underground service cable for a 120/240 volt service. For other voltages, cables or multiple cables consult your local utility.
14. A marker tape shall be installed, above the conduit, 12 inches below grade. Type USE cable shall be marked or listed sunlight resistant.
15. A side bus bar meter socket is required if either 350MCM (or larger) cable or a double run of cable is used.
16. URD Service Risers, from a pole-mounted three-phase transformer bank, shall be limited to an 800 amp rating. Larger services shall be supplied by a padmounted transformer.
17. Customer must provide sufficient cable to reach the transformer or secondary cable and to make connections.

	<b>VERMONT UTILITIES ELECTRIC SERVICE REQUIREMENTS</b>	App'd: <i>YES</i> DATE: 04/22 201pg3c.doc	DRAWING NUMBER 201 Page 3
---	--	---	------------------------------

# POLE METERING

CHECK WITH LOCAL UTILITY TO SEE WHERE APPLICABLE.

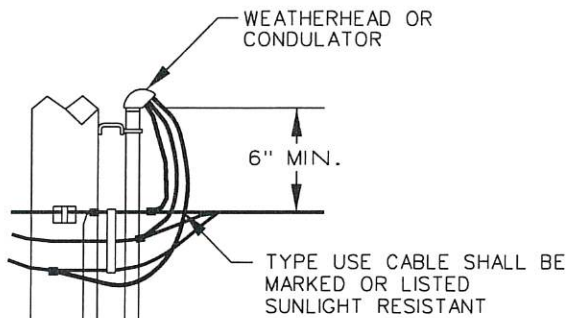

RESIDENTIAL SERVICES ONLY			
RATING	CABLE LENGTH*	TRIPLEX SIZE	CONDUIT
100 A	0-210 FT.	1/0	2 1/2"
	211-410 FT.	4/0	2 1/2"
	411-650 FT.	350 MCM	3"
150 A	0-275 FT.	4/0	2 1/2"
	276-435 FT.	350 MCM	3"
200 A	0-205 FT.	4/0	2 1/2"
	206-325 FT.	350 MCM	3"
300 A	0-220 FT.	350 MCM	3"

\* Cable Length is the total of trench and riser lengths. This chart does not indicate that the cable can be pulled into conduits of these lengths. Pulling tension calculations are necessary to make  $\beta$  that determination.

**SEE NOTES ON THE BACK OF THIS PAGE.**

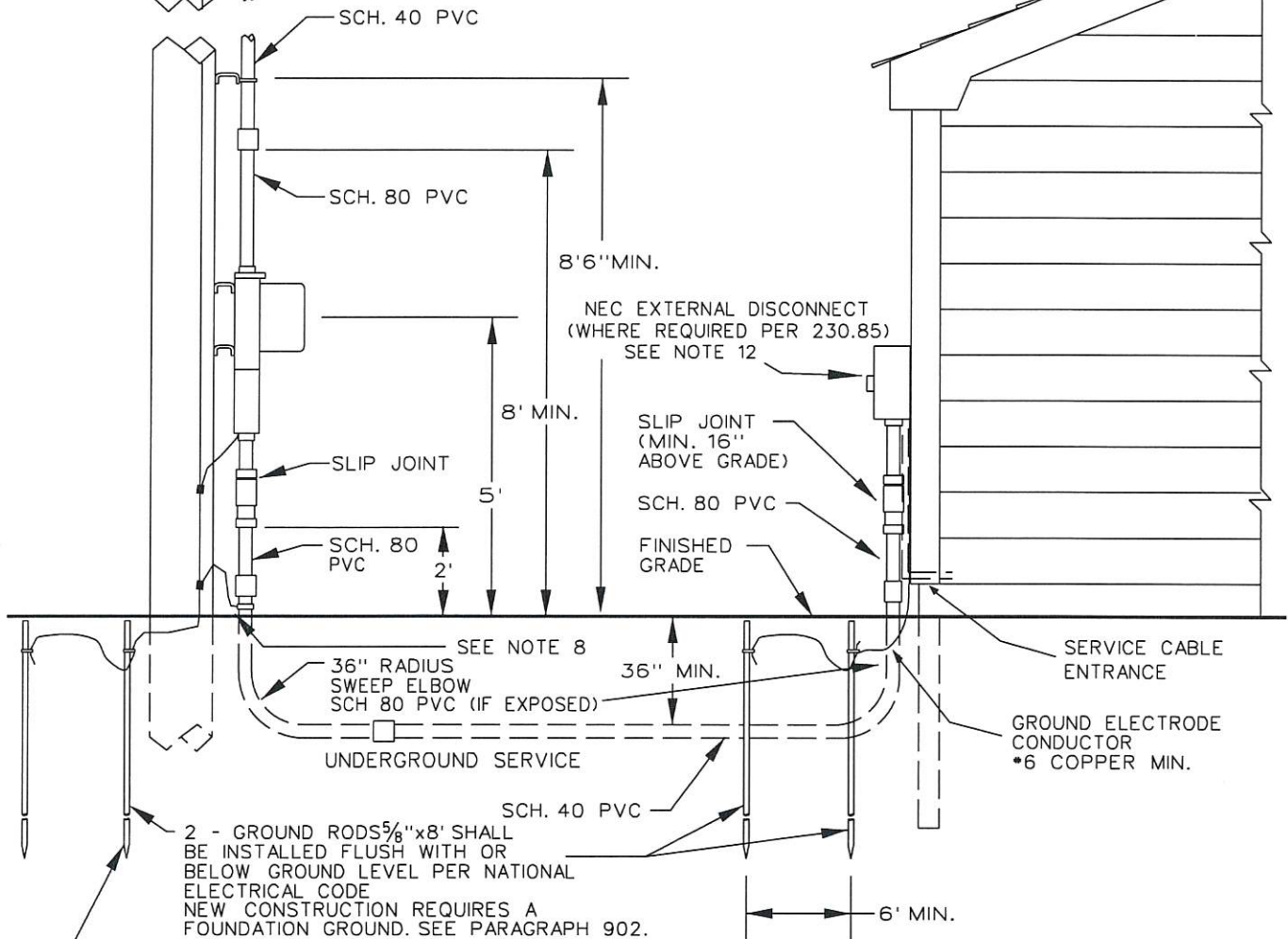

**VERMONT UTILITIES  
ELECTRIC SERVICE REQUIREMENTS**

DRAWN: <i>RJS</i>	DATE: 04-01-22
APPRVD: <i>YES</i>	DATE: 04-01-22
DRAWING No.: 202	PAGE: 1
DATA BASE No.: DTW01892g	

# POLE METERING

## Notes:

1. All wiring and materials shall conform to the requirements of the National Electric Code (NEC) and to any applicable local codes. Where conflict exists the more stringent code will apply. For customer owned equipment, any requirements in excess of code specified minimums, are recommended not required.
2. This specification covers residential services. Commercial service equipment is under the jurisdiction of the electrical inspector. The cable sizes shown in the chart may not apply to commercial services.
3. The location of the conduit risers and the meter socket will be designated by the utility representative. Any relocation shall be approved by a utility representative.
4. Conduit Condulators may be required for multi-conductor services and for conductors of 350 MCM or larger. Exercise care in limiting water entry.
5. Locate the riser conduit on the quarter of the pole away from normal traffic.
6. Residential 320 amp meter sockets, and all commercial meter sockets, shall have a manual bypass. For Utility-specific details see Paragraph 705E. The meter socket shall have a separate grounding electrode conductor connector. The connector shall be appropriately connected to the service neutral bus. The service neutral, and not the grounding electrode conductor, shall extend from the meter socket to the main disconnect in the building. An exception would occur if a breaker, under the meter socket, is the main disconnect for a mobile home. See the Meter Socket Specification (Dwg. 601) included in this manual.
7. The grounding electrode conductor, from the main disconnect, to a driven ground, shall be a minimum of #6 copper. The conductor shall be adequately protected. The driven grounds shown shall be a minimum of 5/8" in diameter and 8' long. See Paragraph 901 through 905 for details of the Service Ground.
8. Any steel conduit within 18" of the surface shall be bonded. Steel conduit is not required.
9. Any construction, at the pole, above ground level, shall be done by the utility company. Exception: The customer may install that portion of their equipment that can be reached while standing on the ground. Any trench near the base of the pole shall be immediately backfilled and properly tamped.
10. Depths shallower than 36" may be allowed where obstructions such as ledge are encountered. Any portion of conduit shallower than 24" shall be covered by a minimum 2" concrete cap. See the utility for additional requirements for conduit buried near underground facilities, under driveways or roadways, or, for depths shallower than 12".
11. All gas valves shall be a minimum of 10 ft from electric meter equipment. For clearances less than 10 ft see Dwg. 401 and NFPA 58.
12. The Service Disconnecting Means for one and two family dwelling units per the NEC section 230.85 must be located in a readily accessible outdoor location and be marked per the NEC requirements.
13. The chart shows the acceptable total cable length for given service amp ratings and conductors. The chart is based on a maximum 3% voltage drop in an aluminum underground service cable for a 120/240 volt service. For other voltages, cables or multiple cables consult your local utility. The chart is a recommendation, rather than a requirement, in the case of Pole Metering. However, failure to follow these recommendations can cause damage or malfunction of the customer's equipment. The Utility does not accept any liability for loss or damage incurred as a result of said failure, and, the customer proceeds at his own risk. The conduit attached to the pole shall meet the chart's size, for the cable chosen by the customer. The cable size shall, at a minimum, meet the ampacity of the customer's disconnect.
14. A marker tape shall be installed, above the conduit, 12 inches below grade. Type USE cable shall be listed or marked sunlight resistant.
15. The decision to allow pole metering is solely at the Utility's discretion. The pole shall be in a location that is protected from pedestrian and vehicular traffic. The pole shall be in a location that is convenient for meter reading. The pole shall not be encumbered with equipment, primary taps or other risers, that make future pole replacements difficult. Pole metering is not available for customers with multiple service rates, or, for customers with time-of-day rates controlled by a relay in the meter.
16. The Utility recommends that the customer install an integral breaker/meter socket. The purpose of the breaker is to allow the customer to maintain their underground service without an expensive linecrew visit. Check with your Utility to determine whether the breaker is required.

	<b>VERMONT UTILITIES ELECTRIC SERVICE REQUIREMENTS</b>	App'd: <i>YES</i> DATE: 12/20 202pg2e.doc	<u>DRAWING NUMBER</u> 202 Page 2
---	--	---	-------------------------------------

# TYPICAL METER PEDESTAL

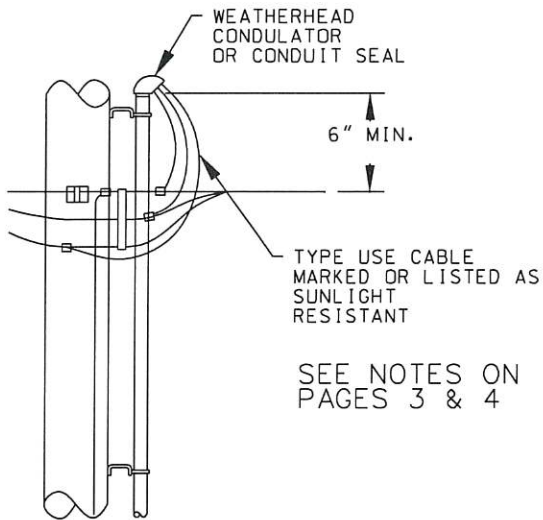

SEE NOTES ON PAGES 3 & 4

RESIDENTIAL 120/240 VOLT SERVICES ONLY			
RATING	CABLE LENGTH*	TRIPLEX SIZE	CONDUIT
100A	0-210 FT.	1/0	2 1/2"
	211-410 FT.	4/0	2 1/2"
	411-650 FT.	350 MCM	3"
150 A	176-275 FT.	4/0	2 1/2"
	276-435 FT.	350 MCM	3"
200A	0-205 FT.	4/0	2 1/2"
	206-325 FT.	350 MCM	3"
300A	0-220 FT.	350 MCM	3"

\* Cable Length is the total of trench and riser lengths. This chart does not indicate that the cable can be pulled into conduits of these lengths. Pulling tension calculations are necessary to make that determination.

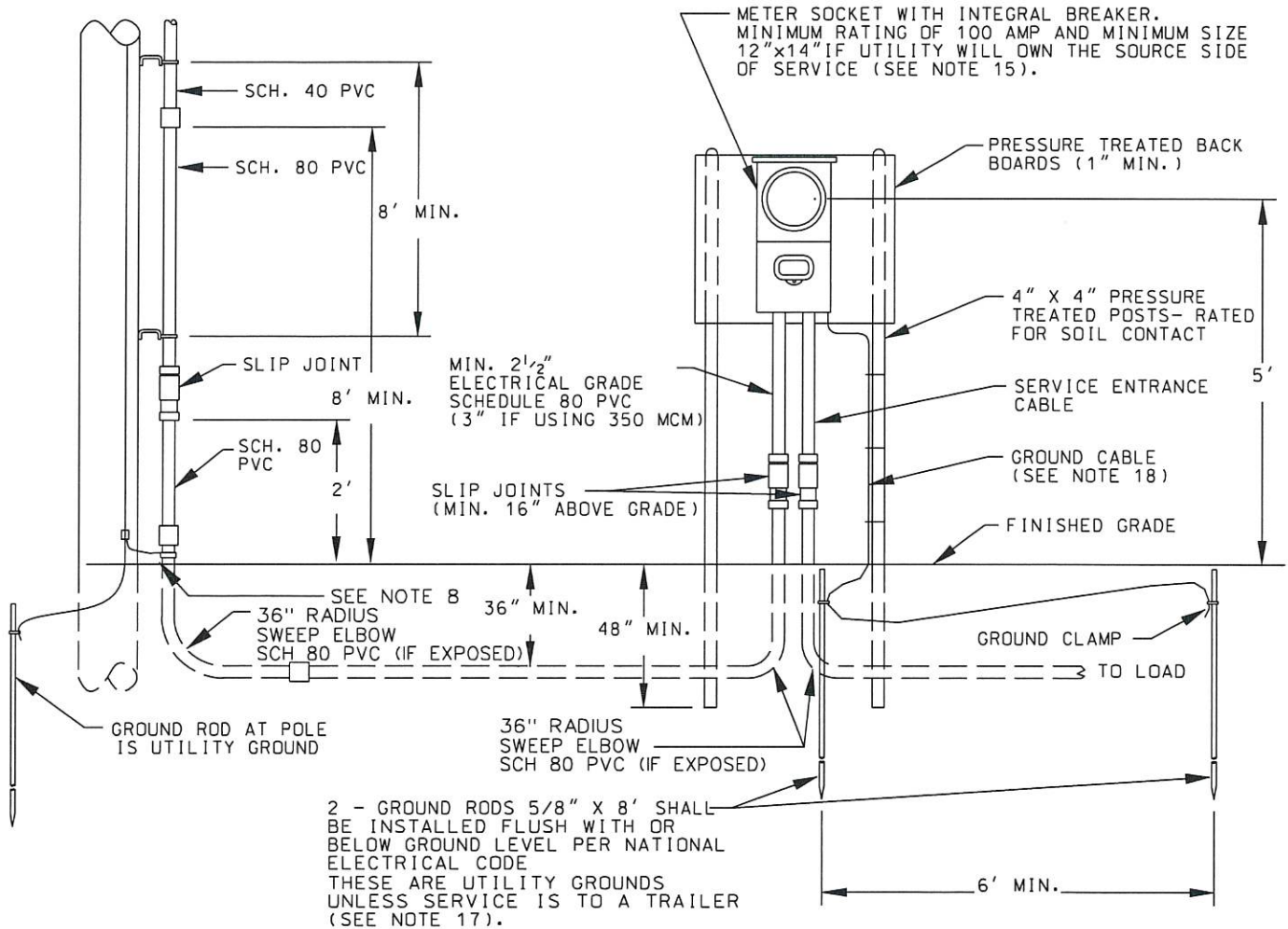

VERMONT UTILITIES  
ELECTRIC SERVICE REQUIREMENTS

DRAWN: LAW	DATE: 01-08-09
APPRVD: JES	DATE: 01-08-09
DRAWING No.: 204	PAGE: 1 of 4
DATA BASE No.: DTW01894g	

# TYPICAL METER PEDESTAL

RESIDENTIAL 120/240 VOLT SERVICES ONLY			
RATING	CABLE LENGTH*	TRIPLEX SIZE	CONDUIT
100A	0-210 FT.	1/0	2 1/2"
	211-410 FT.	4/0	2 1/2"
	411-650 FT.	350 MCM	3"
150 A	176-275 FT.	4/0	2 1/2"
	276-435 FT.	350 MCM	3"
200A	0-205 FT.	4/0	2 1/2"
	206-325 FT.	350 MCM	3"
300A	0-220 FT.	350 MCM	3"

IF THE TRANSFORMER IS IN CLOSE PROXIMITY TO THE METER/DISCONNECT, CONFIRM THAT THE BREAKER IS RATED FOR THE AVAILABLE FAULT CURRENT.

\* Cable Length is the total of trench and riser lengths. This chart does not indicate that the cable can be pulled into conduits of these lengths. Pulling tension calculations are necessary to make that determination.

SEE NOTES ON FOLLOWING PAGES

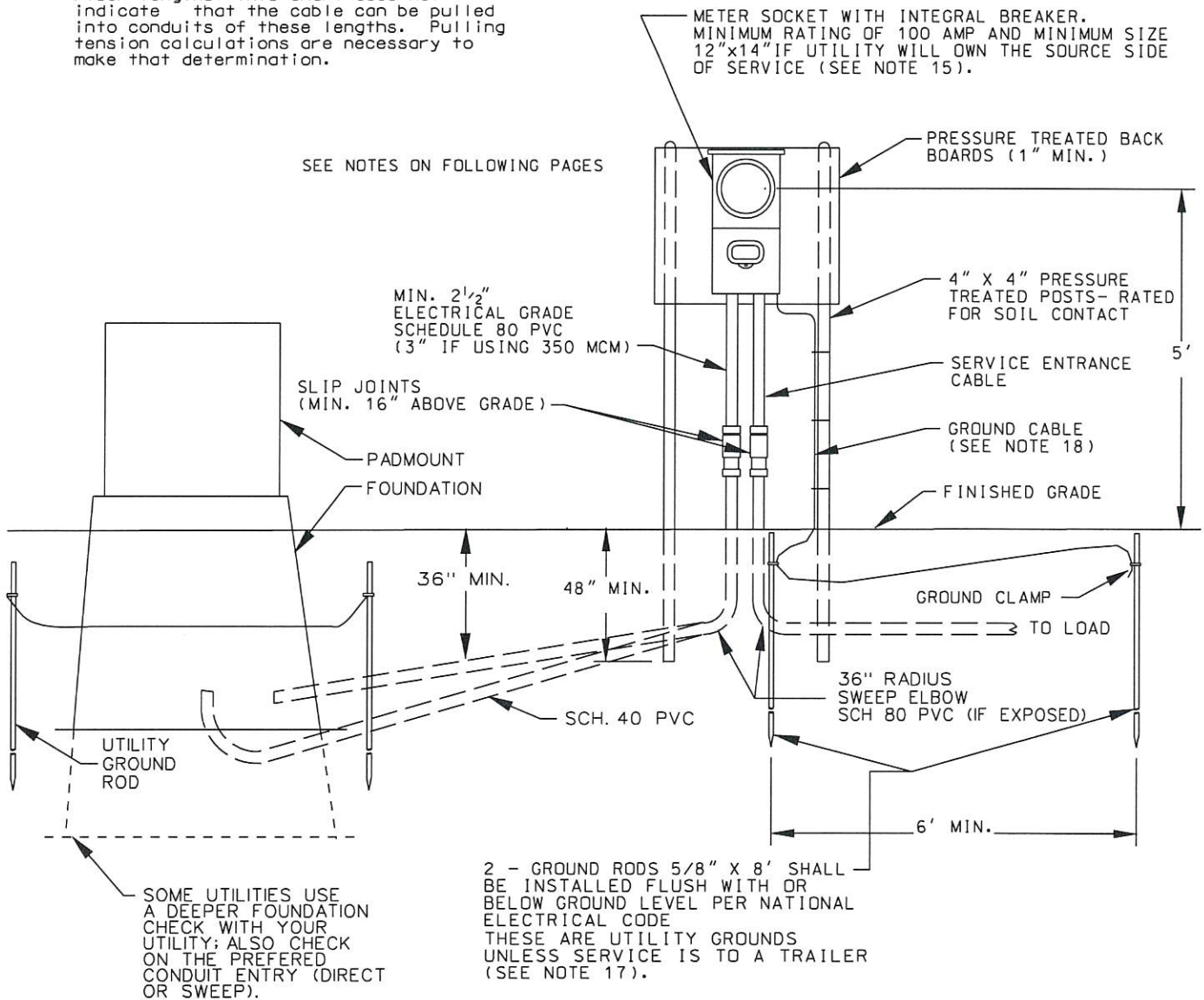

**VERMONT UTILITIES  
ELECTRIC SERVICE REQUIREMENTS**

DRAWN: LAW	DATE: 12-02-08
APPRVD: NES	DATE: 12-02-08
DRAWING No.: 204	PAGE: 2 of 4
DATA BASE No.: DTW01894.2a	

# TYPICAL METER PEDESTAL

## Notes:

1. All wiring and materials shall conform to the requirements of the National Electric Code (NEC) and to any applicable local codes. Where conflict exists the more stringent code will apply. For customer owned equipment, any requirements in excess of code specified minimums, are recommended not required.
2. This specification covers residential services. Commercial service equipment is under the jurisdiction of the electrical inspector. The cable sizes shown in the chart may not apply to commercial services.
3. The location of the meter pedestal and conduit risers and the meter socket will be designated by the utility representative. There shall be no more than three ninety-degree bends in the conduit, including one at the pole/pad and another at the meter pedestal. Any relocation shall be approved by a utility representative.
4. Locate the riser conduit on the quarter of the pole away from normal traffic.
5. The pedestal shall be a minimum of 10 feet from the pole or padmount transformer, and, 5 feet from the mobile home.
6. All gas valves shall be a minimum of 10 ft from electric meter equipment. For clearances less than 10 ft, see Drawing No. 401 in this manual or refer to NFPA 58.
7. The customer shall supply and install the pedestal, conduit, meter socket/disconnect and grounding. A pull rope having a minimum pull strength of 500 lbs. is required to be installed in the conduit by the customer if the Utility supplies the cable. If the customer supplies the cable, it shall be installed in the conduit, and connected to the meter socket.
8. Any steel conduit within 18" of the surface shall be bonded. Steel conduit is not required.
9. The trench should be dug a minimum of 18 inches wide and 36 inches deep to the top of the conduit.
10. Depths shallower than 36" may be allowed where obstructions such as ledge are encountered. Any portion of conduit shallower than 24" shall be covered by a minimum 2" concrete cap. See the Utility for additional requirements for conduit buried near underground facilities, under driveways or roadways, or, for depths shallower than 12".
11. A marker tape shall be installed, above the conduit, 12 inches below grade. Type USE cable shall be listed or marked sunlight resistant.
12. Any construction, at the pole, above ground level, shall be done by the utility company. Exception: The customer may install that portion of their equipment that can be reached while standing on the ground. Any trench near the base of the pole shall be immediately backfilled and properly tamped.
13. The chart shows the acceptable total cable length for given service amp ratings and conductors. The chart is based on a maximum 3% voltage drop in an aluminum underground service cable for a 120/240 volt service. For other voltages, cables or multiple cables consult your local Utility.
14. Residential 320 amp meter sockets, and all commercial meter sockets, shall have a manual bypass. For Utility-specific details see Paragraph 705E. The meter socket shall have a separate grounding electrode conductor connector. The connector shall be appropriately connected to the service neutral bus. The service neutral, and not the grounding electrode conductor, shall extend from the meter socket to the main disconnect in the building. An exception would occur if a breaker, under the meter socket, is the main disconnect for a mobile home. See the Meter Socket Specification (Dwg. 401) included in this manual.
15. A side bus bar meter socket and 3 inch conduit are required if either 350 MCM cable (or larger) or a double run of cable is used.
16. The Service Disconnecting Means for one and two family dwelling units per the NEC section 230.85 must be located in a readily accessible outdoor location and be marked per the NEC requirements.
17. A disconnect is required to be within 30 feet of a mobile home. Four wire services are required from the disconnect to the subpanel (in the mobile home). The breaker in the disconnect shall be sized to protect the feeder to the subpanel. Modular homes, rated by the manufacturer 'For Permanent Foundation', may have the meter socket mounted directly on the structure.
18. The grounding electrode conductor, from the main disconnect, to a driven ground, shall be a minimum of #6 copper. The conductor shall be adequately protected. The driven grounds shown shall be a minimum of 5/8" in diameter and 8' long. See Paragraph 901 through 905 for details of the Service Ground.
19. The Utility recommends that the customer install an integral breaker/meter socket. The purpose of the breaker is to allow the customer to maintain their underground service without an expensive linecrew visit. Check with your Utility to determine whether the breaker is required.
20. Where subject to state or local electrical inspection, such inspection must be made prior to energizing.

	<b>VERMONT UTILITIES ELECTRIC SERVICE REQUIREMENTS</b>	App'd: <i>YES</i> DATE: 04/22 204pg3e.doc	DRAWING NUMBER 204 Page 3
---	--	---	------------------------------

# TYPICAL METER PEDESTAL

**Notes:**

21. The drawing pictures two 4x4 pressure treated posts comprising the support for the meter pedestal. The posts are labeled 'rated for soil contact'. That description, or more completely, 'Ground Contact and Fresh Water Use' is from the wood preservative treatment standard AWPA C2. 'Ground Contact' rated posts are acceptable. A lesser level of treatment, 'Above Ground', which is not intended to be in contact with soil, are not acceptable. A higher level of treatment 'Permanent Wood Foundation,' is preferred, because the timbers will have the longest life. There are several types of preservative chemicals referenced in this standard. Generally, this Manual does not specify which types of treatment may be used; however, posts treated with creosote, are strongly discouraged.

22. Currently available copper-based preservatives are very corrosive to steel items embedded in, and in contact with, the treated timber. Use stainless steel fasteners, and place a permanent barrier between the meter socket and the post.

23. Other factors, affecting the durability of a pedestal installation, are the depth of burial, the surface area of the post exposed to the soil, the type of backfill material, and the compression of the backfill material. Increasing the quality of these factors will result in a pedestal that is less likely to be overturned, by forces experienced in the environment.

24. Supports of descriptions, other than two 4x4 pressure treated posts (rated for soil contact) and buried 48" (min.) depth, may be preferred, or allowed, by particular Utilities. The alternative supports, listed below, are examples. The Customer/Contractor may suggest other alternative methods; however, the Utility retains the right to make a determination of acceptability.

- a) Larger dimension pressure treated wood (PTW) posts
- b) Posts with a greater burial depth
- c) Single posts supporting, at most, two sockets, on opposite sides of post
- d) Concrete posts
- e) Structural fiberglass, plastic, or plastic/wood posts
- f) Rigid hot-dipped galvanized steel conduit (RGSC) (minimum 2" dia.) posts. Individual conduit supports shall not be used as both a support and as a wire conduit. The two posts shall be embedded in 8" diameter-48" depth (minimum) concrete footings. The socket's neutral bus (and the socket) shall be connected to grounding electrodes and the posts shall be bonded to the socket, by metal Unistrut socket supports. The two posts shall be capped.
- g) Manufactured metal meter pedestals, direct embedded or mounted on concrete slab
- h) Socket support of pressure treated boards, or metal Unistrut, between the two posts

Meter Pedestal Variations	Applicability by Utility							
	GM	VE	WE	LE	HE	VJ	NE	ST
Meter Pedestals for other than Mobile Homes	O	U	O	N	U	U	O	O
Two 4"x4" PTW Posts set 48" deep	O	U	P	P	P	O	O	O
Two 6"x6" PTW Posts set 48" deep	O	P	O	O	O	P	O	O
One 4"x12" PTW Posts set 60" deep (2 sockets max.)	O	U	N	O	N	N	O	O
One 8"x8" PTW Posts set 60" deep (2 sockets max.)	O	U	N	O	N	N	O	O
Two 2" RGSC Posts set in concrete 48" deep	O	O	N	O	N	O	N	O
Alternate Materials (concrete, fiberglass, etc.)	U	U	N	U	U	U	U	U
Manufactured Metal Pedestal direct embedded	N	N	N	N	N	N	N	N
Manufactured Metal Pedestal on concrete slab	O	O	N	O	O	O	N	O
Other Supports Suggested by Customer/Contractor	U	U	N	U	U	U	U	U
PTW Board Socket Support (no plywood)	O	P	O	O	O	O	O	O
Unistrut Socket Support	O	O	N	O	O	O	O	U

U- Utility Option, O- Customer Option, P- Preferred Option, N- Not Available as an Option

# TYPICAL METER PEDESTAL FOR CURRENT TRANSFORMER METER

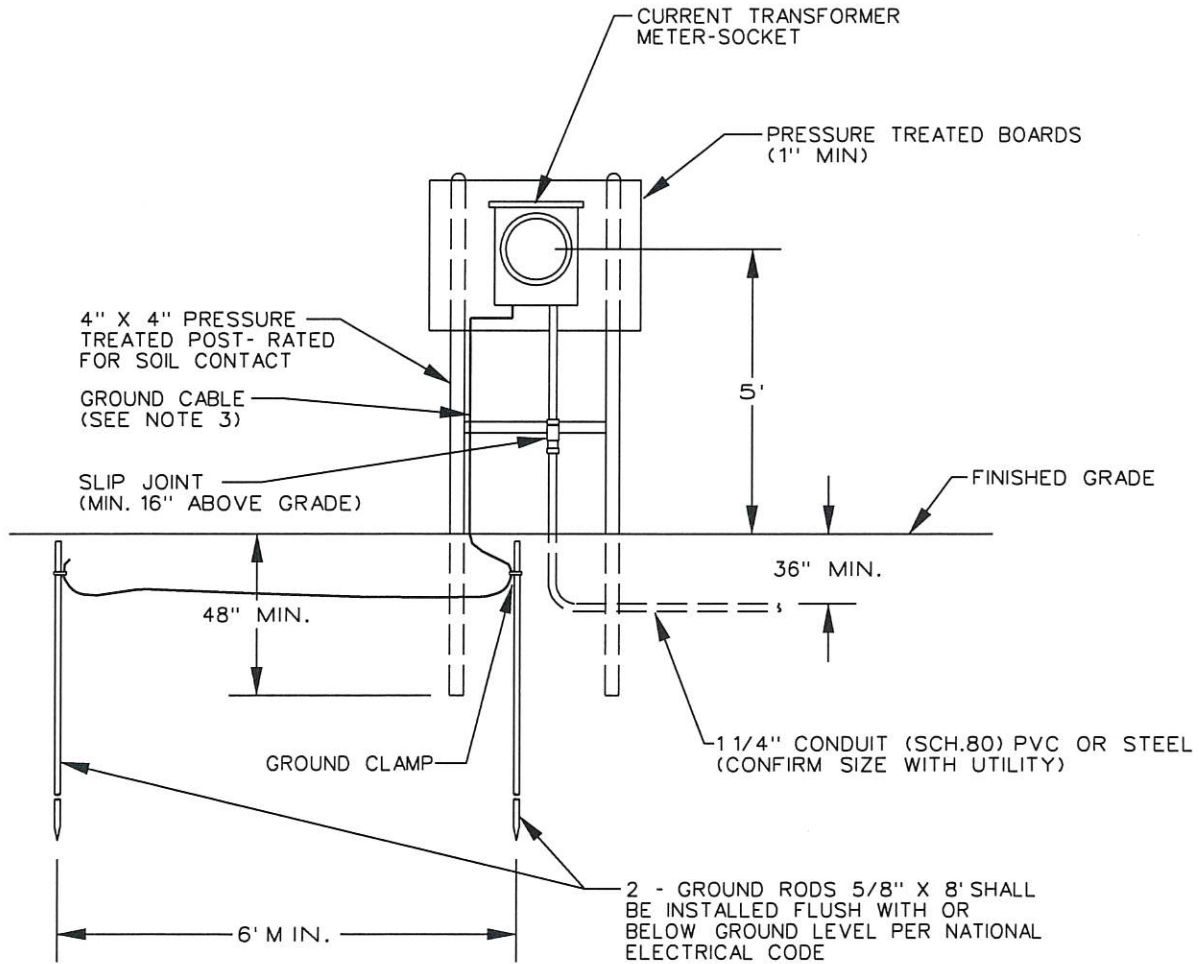

**NOTES:**

1. Location of the pedestal will be designated by a Utility representative.
2. 4" X 4" pressure treated wood posts shall be rated for soil contact.
3. A minimum #6 copper ground cable must be connected in the meter socket, to its own ground terminal.
4. Pedestal shall be located a minimum of 10' from pole or pad mounted transformer.

DRAWN: LAW	DATE: 01-01-07
APPRVD: <i>RES</i>	DATE: 01-19-07
DRAWING No.: 205	PAGE: 1
DATA BASE No.: DTW01895c	

# TYPICAL MULTIPLE METER PEDESTAL

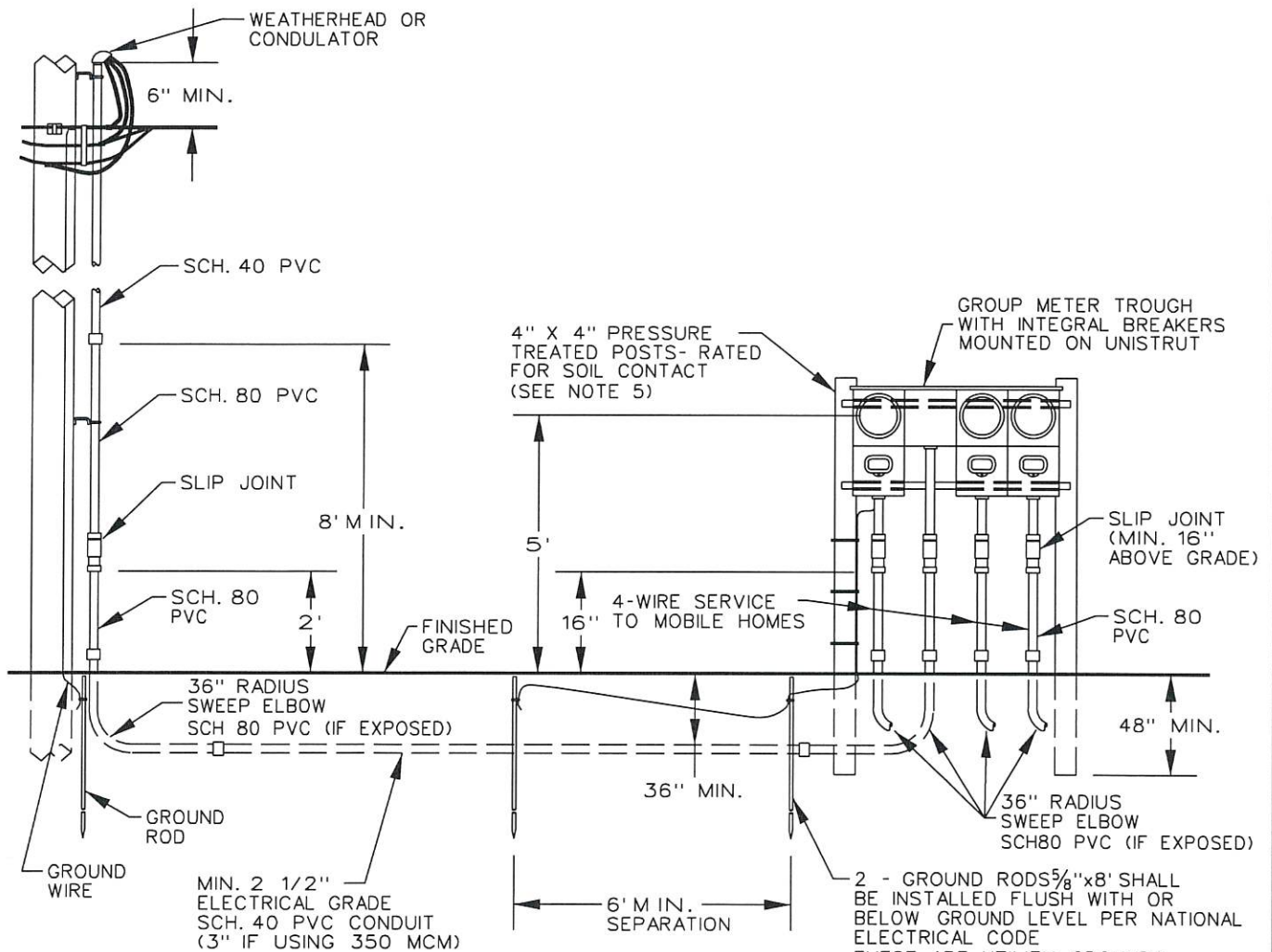

## NOTES:

1. THE LOCATION OF THE PEDESTAL WILL BE DESIGNATED BY A UTILITY REPRESENTATIVE. THERE SHALL BE NO MORE THAN 3 NINETY-DEGREE BENDS IN THE CONDUIT, INCLUDING ONE AT THE POLE/PAD AND ANOTHER AT THE PEDESTAL.
2. TRENCH SHOULD BE DUG A MINIMUM OF 18 INCHES WIDE AND 36 INCHES DEEP, TO THE TOP OF CONDUIT.
3. THE CUSTOMER SHALL SUPPLY AND INSTALL THE PEDESTAL, CONDUIT, METER SOCKET/DISCONNECT, AND GROUNDING. A PULL ROPE, HAVING A MINIMUM PULL STRENGTH OF 500 LBS. IS REQUIRED TO BE INSTALLED IN THE CONDUIT BY THE CUSTOMER IF THE UTILITY SUPPLIES THE CABLE. IF THE CUSTOMER SUPPLIES THE CABLE, IT SHALL BE INSTALLED IN THE CONDUIT, AND CONNECTED IN THE METER SOCKET.
4. A SIDE BUS BAR METER SOCKET AND 3 INCH CONDUIT ARE REQUIRED IF EITHER 350MCM CABLE (OR LARGER) OR A DOUBLE RUN OF CABLE IS USED.
5. 4"X4" PRESSURE TREATED WOOD POSTS SHALL BE RATED FOR SOIL CONTACT.
6. THE GROUND CABLE MUST BE CONNECTED IN THE METER SOCKET, TO ITS OWN GROUND TERMINAL. THE GROUNDING CONDUCTOR SHALL BE A MINIMUM OF #6 COPPER. TWO GROUND RODS ARE REQUIRED.
7. THE PEDESTAL SHALL BE LOCATED A MINIMUM OF 10 FEET FROM THE POLE OR PADMOUNTED TRANSFORMER; AND, IT SHALL BE A MINIMUM OF 5 FEET FROM A MOBILE HOME.
8. MOBILE HOMES AND MANUFACTURED HOMES:  
A DISCONNECT IS REQUIRED TO BE WITHIN 30 FEET OF A MOBILE HOME. FOUR WIRE SERVICES ARE REQUIRED FROM THE DISCONNECT TO THE SUBPANEL (IN THE MOBILE HOME). THE BREAKER IN THE DISCONNECT SHALL BE SIZED TO PROTECT THE FEEDER TO THE SUBPANEL. MANUFACTURED HOMES, RATED BY THE MANUFACTURER 'FOR PERMANENT FOUNDATION' MAY HAVE THE METER SOCKET MOUNTED DIRECTLY ON THE STRUCTURE.
9. WHERE SUBJECT TO STATE OR LOCAL ELECTRICAL INSPECTION, SUCH INSPECTION MUST BE MADE PRIOR TO ENERGIZATION.
10. CONDUIT CONDULATORS MAY BE REQUIRED FOR MULTI-CONDUCTOR SERVICES AND FOR CONDUCTORS OF 350MCM OR LARGER. EXERCISE CARE IN LIMITING WATER ENTRY.
11. A MARKER TAPE SHALL BE INSTALLED, ABOVE THE CONDUITS, 12 INCHES BELOW GRADE. TYPE USE CABLE SHALL BE MARKED OR LISTED SUNLIGHT RESISTANT.

**VERMONT UTILITIES  
ELECTRIC SERVICE REQUIREMENTS**

DRAWN: LAW	DATE: 04-01-22
APPRVD: JES	DATE: 04-01-22
DRAWING No.: 206	PAGE: 1
DATA BASE No.: DTW01896f	

# TYPICAL TEMPORARY SERVICE

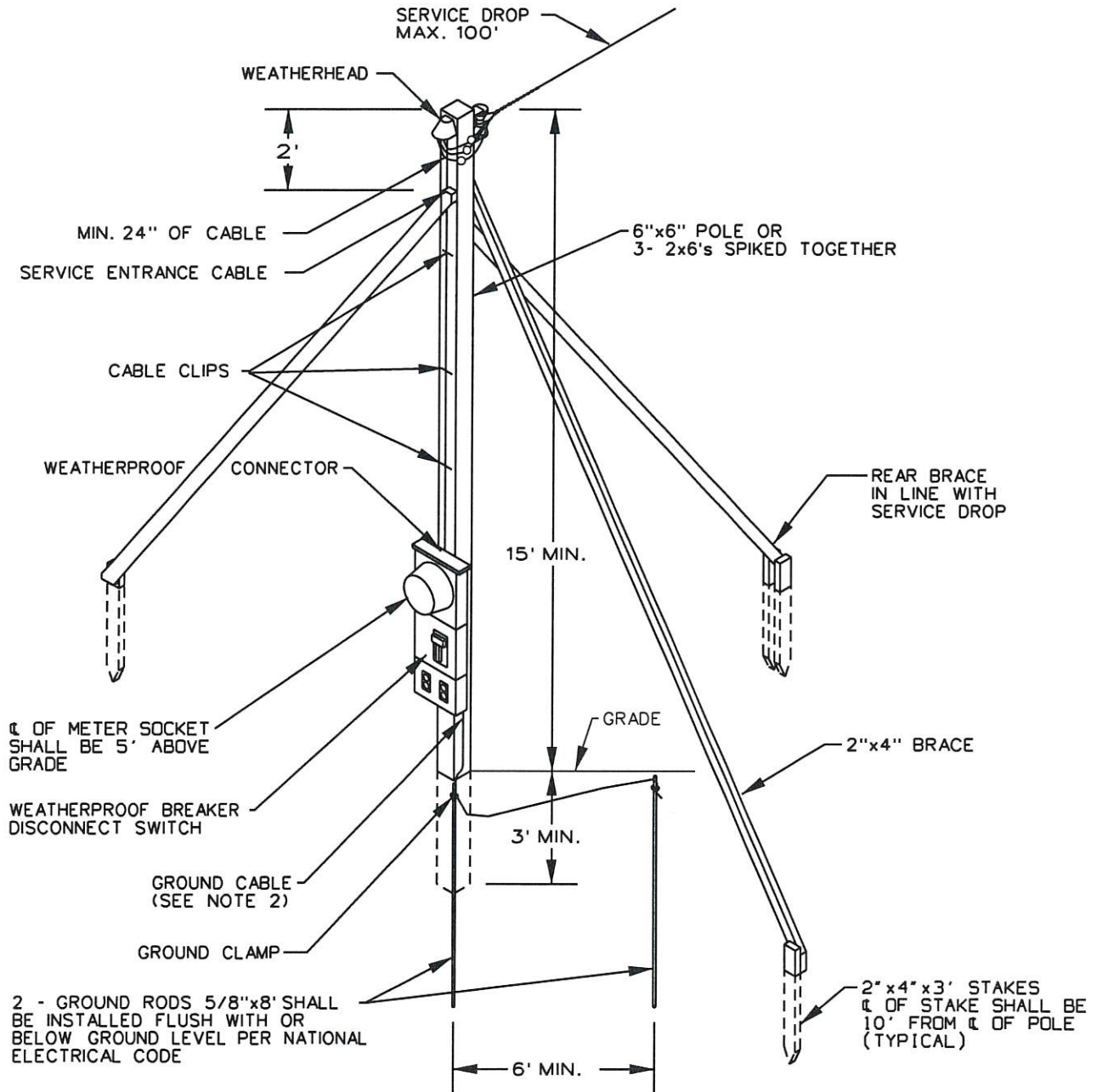

## NOTES:

1. A minimum of 18' clearance is required above all roads, streets, nonresidential driveways, parking lots and other land traversed by vehicles.
2. A minimum #6 copper ground cable must be connected in the meter socket, to its own ground terminal. The grounding electrode conductor shall be adequately protected.
3. Temporary service is limited to a six month time period unless extension is approved by Utility.
4. Rain tight service equipment, with ground fault protection and provision for locking, and all other materials and equipment to be owned and installed by customer. Utility to install meter and service drop and connect service drop at weatherhead.
5. Service location and type of construction must be approved in advance by Utility.
6. Where subject to state or local electrical inspection, such inspection must be made prior to energizing.

VERMONT UTILITIES  
ELECTRIC SERVICE REQUIREMENTS

DRAWN: LAW	DATE: 01-01-07
APPRVD: <del>DES</del>	DATE: 01-19-07
DRAWING No.: 301	PAGE: 1
DATA BASE No.: DTW01897a	

# TYPICAL TEMPORARY UNDERGROUND SERVICE

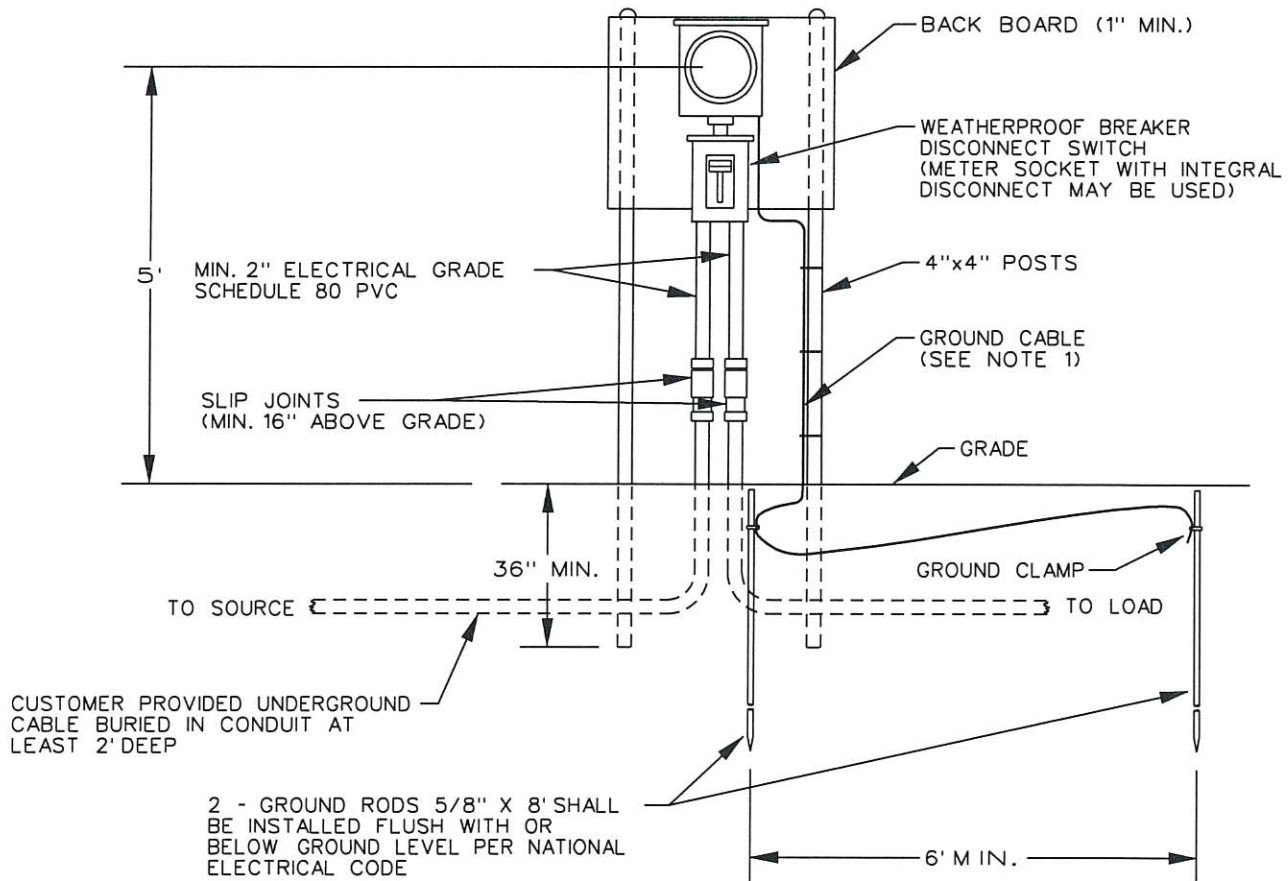

## NOTES:

1. A minimum #6 copper ground cable must be connected in the meter socket to its own ground terminal. The grounding electrode conductor shall be adequately protected.
2. Temporary service is limited to six month time period unless extension is approved by Utility.
3. Rain tight service equipment, with ground fault protection (per NEC) with provision for locking. Check with local Utility as to who will supply hardware. Utility will install meter and make service connection.
4. Service location and type of construction must be approved in advance by Utility.
5. Where subject to state or local electrical inspection, such inspection must be made prior to energizing.
6. In order to limit the FAULT AMP CURRENT to less than 10,000 amps at the breaker, this pedestal shall be located a sufficient distance from the transformer. Example being 20 feet of #2 Alc. service cable.

VERMONT UTILITIES  
ELECTRIC SERVICE REQUIREMENTS

DRAWN: LAW	DATE: 01-01-07
APPRVD: <i>DES</i>	DATE: 01-19-07
DRAWING No.: 302	PAGE: 1
DATA BASE No.: DTW01898a	

# TYPICAL TRENCH CROSS-SECTION U.G. CABLE IN CONDUIT

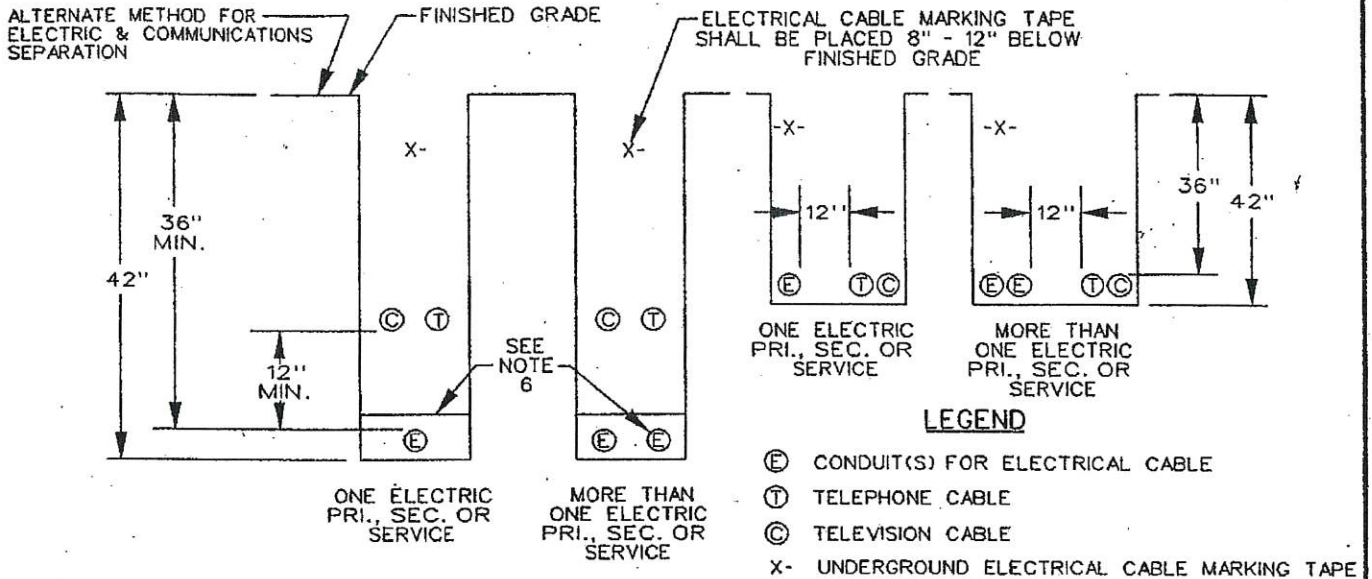

## NOTES:

1. ALL TRENCHES AND ELECTRICAL CONDUIT(S) REQUIRE APPROVAL BY UTILITY INSPECTOR BEFORE BACKFILLING.
2. ALL TRENCHES SHALL BE 18 INCH MINIMUM WIDTH. THE CONDUIT SHALL BE EMBEDDED IN UNFROZEN SAND OR FINE GRAVEL, THAT WILL PASS A 1 INCH MESH. THIS MATERIAL SHALL BE A MINIMUM OF 4 INCHES THICK ON ALL SIDES OF THE CONDUIT. THE REMAINDER OF THE BACKFILL SHALL BE CLEAN, AND, SHALL NOT CONTAIN ROCKS LARGER THAN 8 INCHES IN ANY DIMENSION. CAREFULLY COMPACT THE FULL DEPTH OF BACKFILL, UNDER TRAVELLED WAYS AND PARKING LOTS. THE MINIMUM DEPTH, UNDER A HIGHWAY, SHALL BE 48 INCHES RATHER THAN 36 INCHES. MOUNDING THE TRENCH, TO PROVIDE THE REQUIRED DEPTH, IS NOT ALLOWED.
3. CONDUIT SHALL BE ENCASED IN A 4 INCH ENVELOPE OF CONCRETE UNDER THE FOLLOWING CONDITIONS:
  - A) BROOK CROSSINGS.
  - B) CROSSINGS OF WATER, SEWER, AND GAS PIPELINES. CROSSINGS SHALL BE DONE AT NINETY DEGREES IF POSSIBLE. NORMALLY, THE ELECTRICAL CONDUIT SHALL BE A MINIMUM OF 18 INCHES ABOVE THE PIPE. CAREFULLY COMPACT THE FILL BELOW THE ELECTRICAL CONDUIT. CONCRETE ENCASEMENT IS REQUIRED FOR 10 FEET ON EACH SIDE OF THE PIPE.
  - C) UNDER THE TRAVELLED WAY OF CITY STREETS, AND, UNDER TOWN HIGHWAYS, IF REQUIRED BY THE TOWN, A PIPE SLEEVE, SURROUNDING THE CONDUIT, MAY BE SUBSTITUTED.
  - D) CONDUITS WITHIN 20 FEET OF TANKS CONTAINING FUELS, OR SOLVENTS. THESE TANKS MAY BE ABOVE OR BELOW GRADE. THIS REQUIREMENT DOES NOT APPLY TO URD SERVICES.
4. TRENCHES SHOULD BE LOCATED 10 FEET FROM ANY STRUCTURE, UNLESS THE CONDUIT IS GOING TO THE STRUCTURE. CONTACT THE UTILITY IF CLOSER APPROACHES ARE NECESSARY.
5. TRENCHES SHOULD BE LOCATED 10 FEET FROM ANY WATER, SEWER, OR GAS PIPELINE THAT PARALLELS THE CONDUIT. CONTACT THE UTILITY IF CLOSER APPROACHES ARE NECESSARY.
6. COMMUNICATIONS CABLES AND CONDUITS MAY BE LOCATED IN THE SAME TRENCH WITH ELECTRIC CABLES OR CONDUITS. A MINIMUM HORIZONTAL OR VERTICAL SEPARATION OF 12 INCHES IS REQUIRED. ELECTRICAL CONDUITS SHALL BE SEPARATED BY 4 INCHES. THESE DISTANCES ARE MEASURED SURFACE-TO-SURFACE, NOT CENTER-TO-CENTER.
7. DEPTHS SHALLOWER THAN 36 INCHES MAY BE ALLOWED WHERE OBSTRUCTIONS SUCH AS LEDGE ARE ENCOUNTERED. ANY PORTION OF THE CONDUIT SHALLOWER THAN 24 INCHES SHALL BE COVERED WITH A MINIMUM 2 INCH CONCRETE CAP. SEE THE UTILITY FOR DEPTHS SHALLOWER THAN 12 INCHES.

**VERMONT UTILITIES  
ELECTRIC SERVICE REQUIREMENTS**

DRAWN: LAW	DATE: 1-15-00
APPRVD: YES	DATE: 1-15-00
DRAWING No.: 203	PAGE: 7
DATA BASE No.: DTW01893b	

## FOUNDATION CONDUIT INSTALLATION

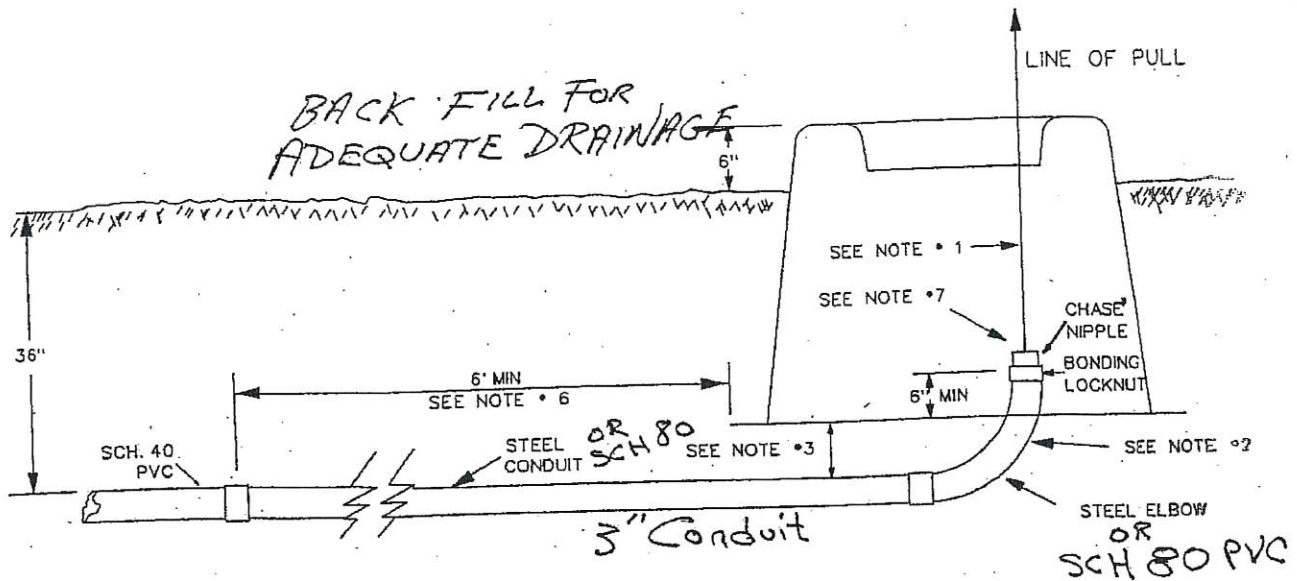

### NOTES:

1. ELBOW MUST BE ALIGNED TO ALLOW STRAIGHT PULL THROUGH BOX PAD OPENING.
2. A 90° ELBOW IS TYPICAL, HOWEVER, CONDITIONS MAY REQUIRE THAT A 45° ELBOW BE SPECIFIED BY ENGINEERING.
3. PROVIDE SUFFICIENT CLEARANCE SO BOX PAD DOES NOT CONTACT ELBOW.
4. A 500# RATED PULL STRING SHALL BE INSTALLED IN THE COMPLETED CONDUIT RUN.
5. CONDUIT END TO BE SEALED, WITH APPROVED DUCT SEAL, AFTER CABLES ARE INSTALLED.
6. STEEL CONDUIT SHALL EXTEND AT LEAST 6 FEET FROM BOX PAD. *or Sch 80*
7. EXPOSED STEEL CONDUIT TO BE BONDED TO GROUND GRID.
8. THIS STANDARD APPLIES TO SINGLE PHASE PADMOUNT AND SINGLE AND THREE PHASE TERMINATING CABINET FOUNDATIONS.
9. *Conduit location, viewed from front, primary on left secondary on right.*

*HEDept*

DISTRIBUTION  
STANDARD

## FOUNDATION SINGLE PHASE BOX PAD

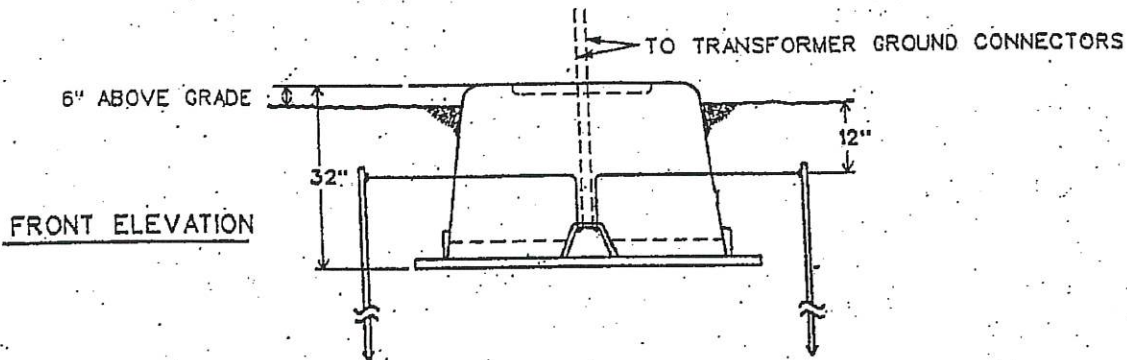
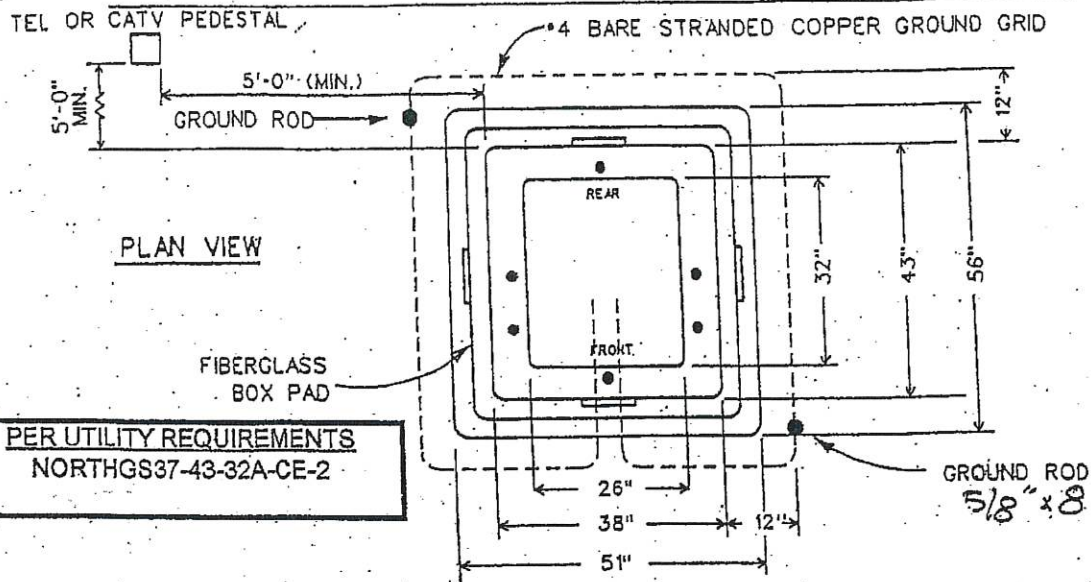

### Notes:

1. Pad shall be protected from vehicular damage by location or suitable barrier. When a barrier is necessary, it shall consist of a minimum 4" diameter steel conduit, concrete filled, installed 3' above and below ground level. Barriers to be customer installed, the quantity and location to be specified by HED or a curb of sufficient height and suitably located that doesn't create a pool.
2. Set fiberglass pad to provide adequate drainage away from pad. If necessary to locate in a low spot, set on a mound a minimum of 18" high with a 1 on 4 slope.
- 2a. Adequate drainage requires crushed stone under pad and drain pipe.
3. The transformer must be secured to its pad by using 2-3/8" bolts with appropriated washers. Terminating cabinets are to be secured to the foundation.
4. Leave slack in primary and secondary cables in open space.
5. Pad dimensions may vary with manufacturer. Foundation dimensions for three phase terminating cabinets vary from those shown.
6. Locate the pad so it's accessible by truck.
7. This standard applies to single phase padmount, single and three phase terminating cabinet foundations.

**HARDWICK  
ELECTRIC**

**DISTRIBUTION  
STANDARD**

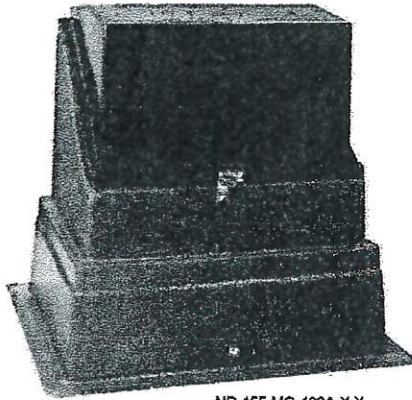

ND-155-MG-102A-X-X

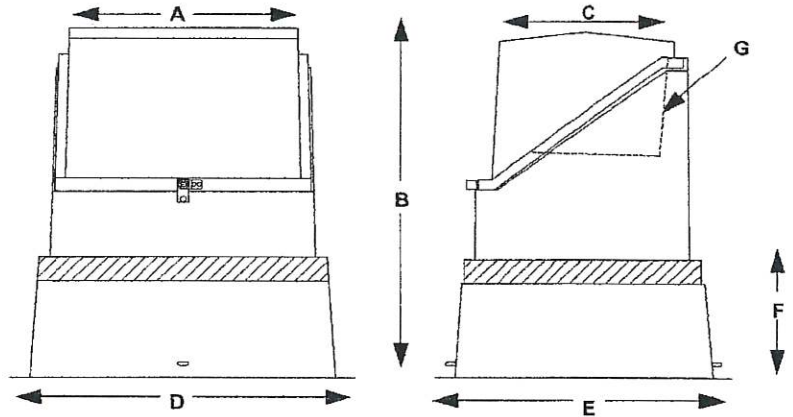

Sectionalizing Cabinets (Hinged)	A Top Width	B Cabinet Height	C Top/ Operating Depth	D Base Width	E Base Depth	F Max. Burial Depth	G Angle	Units per pallet
ND-120-MG-101-X-X	23.5"	35"	22"	39.5"	37"	Pad Mount	5°	3
ND-2155-WG-102A-X-X	31.5"	47" with mounting base	22.5"	56.5"	50.5"	Pad Mount or 18"	5°	2
ND-130-MG-101-X-X	24"	37.5"	20.5"	42"	40.5"	15"	20°	3
ND-135-MG-102A-X-X	30"	36"	18"	43.5"	38.5"	15"	20°	3
ND-150-MG-101-X-X	23.5"	50"	22"	45"	42"	18"	5°	2
ND-155-MG-102A-X-X	31.5"	50.5"	22.5"	50.5"	44.5"	17"	5°	2
ND-301830H-MG-102A-X-X w/ ground sleeve	30"	48.5"	19"	38.5"	28"	18"	5°	4 (w/o GS)

\*\*\*

**Example: ND-150-MG-101-X-X**

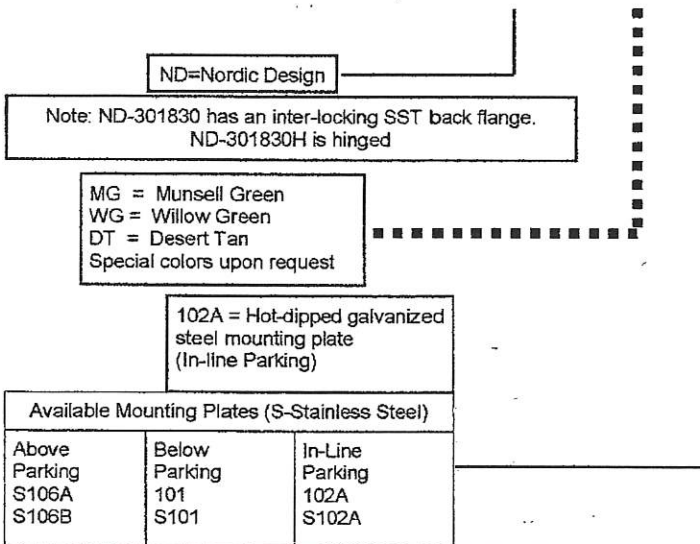

Our PH-1 Penta-Head Wrench can be used for the ND Series cabinets



# TYPICAL METER PEDESTAL

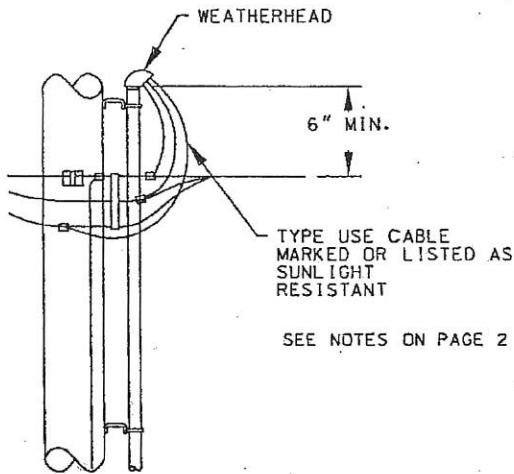

SEE NOTES ON PAGE 2

RESIDENTIAL 120/240 VOLT SERVICES ONLY			
RATING	CABLE LENGTH*	TRIPLEX SIZE	CONDUIT
100A	0-210 FT.	1/0	2 1/2"
	211-410 FT.	4/0	2 1/2"
	411-650 FT.	350 MCM	3"
150 A	176-275 FT.	4/0	2 1/2"
	276-435 FT.	350 MCM	3"
200A	0-205 FT.	4/0	2 1/2"
	206-325 FT.	350 MCM	3"
300A	0-220 FT.	350 MCM	3"

\* Cable Length is the total of trench and riser lengths. This chart does not indicate that the cable can be pulled into conduits of these lengths. Pulling tension calculations are necessary to make that determination.

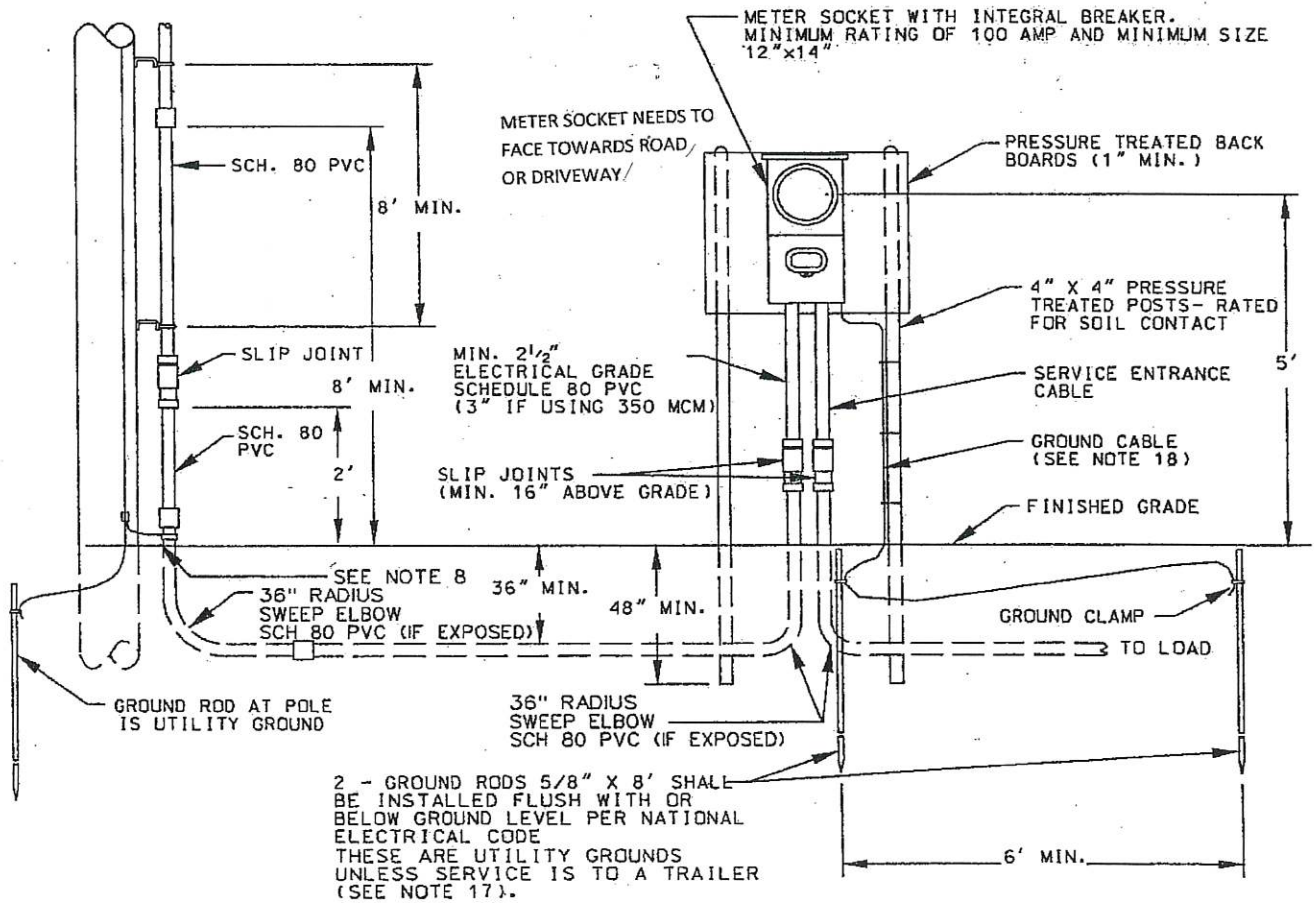

VERMONT UTILITIES  
ELECTRIC SERVICE REQUIREMENTS

DRAWN: LAW	DATE: 11-02-04
APPRVD: YES	DATE: 12-22-04
DRAWING No.: 204	PAGE: 1
DATA BASE No.: DTW01894e	

## Typical Meter Pedestal

**Notes:**

1. All wiring and materials shall conform to the requirements of the National Electric Code (NEC) and to any applicable local codes. Where conflict exists the more stringent code will apply. For customer owned equipment, any requirements in excess of code specified minimums, are recommended not required.
2. This specification covers residential services. Commercial service equipment is under the jurisdiction of the electrical inspector. The cable sizes shown in the chart may not apply to commercial services.
3. The location of the meter pedestal and conduit risers and the meter socket will be designated by the utility representative. There shall be no more than three ninety-degree bends in the conduit, including one at the pole/pad and another at the meter pedestal. Any relocations shall be approved by a utility representative.
4. Locate the riser conduit on the quarter of the pole away from normal traffic.
5. The pedestal shall be a minimum of 10 feet from the pole or padmount transformer, and, 5 feet from the mobile home.
6. All gas valves shall be a minimum of 10 ft from electric meter equipment. For clearances less than 10 ft see NFPA 58.
7. The customer shall supply and install the pedestal, conduit, meter socket/disconnect and grounding. A pull rope having a minimum pull strength of 500 lbs. is required to be installed in the conduit by the customer if the Utility supplies the cable. If the customer supplies the cable, it shall be installed in the conduit, and connected to the meter socket.
8. The trench should be dug a minimum of 18 inches wide and 36 inches deep to the top of the conduit.
9. Depths shallower than 36" may be allowed where obstructions such as ledge are encountered. Any portion of conduit shallower than 24" shall be covered by a minimum 2" concrete cap. See the Utility for additional requirements for conduit buried near underground facilities, under driveways or roadways, or, for depths shallower than 12".
10. A marker tape shall be installed, above the conduit, 12 inches below grade. Type USE cable shall be listed or mark sunlight resistant.
11. Any steel conduit within 18" of the surface shall be bonded. Steel conduit is not required.
12. Any construction, at the pole, above ground level, shall be done by the utility company. Exception: The customer may install that portion of their equipment that can be reached while standing on the ground. Any trench near the base of the pole shall be immediately backfilled and properly tamped.
13. The chart shows the acceptable total cable length for given service amp ratings and conductors. The chart is based on a maximum 3% voltage drop in an aluminum underground service cable for a 120/240 volt service. For other voltages, cables or multiple cables consult your local utility.
14. Commercial meter sockets 200 amps and larger, and all Residential meter sockets requiring 350 MCM wire, shall have a manual bypass. The meter socket shall have a separate grounding electrode conductor connector. The connector shall be appropriately connected to the service neutral bus. The service neutral, and not the grounding electrode conductor shall extend from the meter socket to the main disconnect in the building. An exception would occur in a breaker, under the meter socket, is the main disconnects for a mobile home. See the Meter Socket Specification included in this manual.
15. A bus bar meter socket and 3 inch conduit are required if 350 MCM cable or a double run of cable is used.
16. The Service Disconnecting Means shall be installed at a readily accessible location, either outside of a building or structure, or, inside a building or structure nearest the point of entrance of the service conductors, not to exceed 10 feet of conductor length, from the point of entrance. Local Jurisdiction may specify a shorter distance.
17. A disconnect is required to be within 30 feet of a mobile home. Four wire services are required from the disconnect to the subpanel (in the home). The breaker in the disconnect shall be sized to protect the feeder to the subpanel. Modular homes, rated by the manufacturer 'For Permanent Foundation', may have the meter socket mounted directly on the structure.
18. The grounding electrode conductor, to a driven ground, shall be a minimum of #6 copper. The conductor shall be adequately protected. The driven rods shown shall be a minimum of 5/8" in diameter in 8' long.
19. The Utility recommends that the customer install an integral breaker/meter socket. The purpose of the breaker is to allow the customer to maintain their underground service without an expensive lineworker visit. Check with your Utility to determine whether the breaker is required.
20. Where subject to state or local electrical inspection, such inspection must be made prior to energizing.

**Vermont Utilities**  
**Electric Service Requirements**

App'd: *YES*  
 DATE: 11/04  
 204pg2a.doc

DRAWING NUMBER

204      2 of 2